

THE EFFECT OF HYDROXYAPATITE COATING WITH SILVER NANOPARTICLES ON OSSEOINTEGRATION OF TITANIUM IMPLANTS

JOANNA SULEJ-CHOJNACKA^{1*} , WALDEMAR WOŹNIAK² , DANIEL ANDRZEJEWSKI¹ 

¹ LUKASIEWICZ RESEARCH NETWORK - METAL FORMING INSTITUTE,

14 JANA PAWLA II ST., 61-139 POZNAN, POLAND

² WIKTOR DEGI ORTHOPEDIC AND REHABILITATION CLINICAL HOSPITAL, KAROL MARCINKOWSKI MEDICAL UNIVERSITY, DEPARTMENT OF GENERAL ORTHOPEDICS, ONCOLOGY AND TRAUMATOLOGY,

135-147 28 CZERWCA 1956 R. ST., 61-545 POZNAN, POLAND

*E-MAIL: JOANNA.CHOJNACKA@INOP.POZNAN.PL

Abstract

During the implantation surgery, an infection associated with the biofilm formation may occur. Both the type of the introduced material as well as the implant osseointegration largely determine the effectiveness of bone defect treatment. The materials research is increasingly focusing on improving the osseointegration process. A bacterial biofilm can form on any surface of the artificial organ that has been introduced into the body or surrounding tissues. A bacterial infection is one of the most serious complications of implantology surgery leading to serious physiological damage. As proved in the literature, a solution that can prevent bacterial infections is to modify the implant surface by applying an antibacterial coating, while maintaining the material biocompatibility. The article presents the tests results of prototype implants with hydroxyapatite coatings obtained via plasma spraying on titanium surfaces. The resulting coatings were enriched with silver nanoparticles, the content of which was about 2%. The animal model are New Zealand rabbits. The implants were placed in the femur of the animal. The amount of released ions and the force of pulling the implants from the bone were determined. The binding strength between the joint surface and the implant was determined by the mechanical blocking and biological binding of growing bone tissue. In addition, the surface structure of the obtained implants was evaluated.

It has been shown that the surface modification of the implants affected the obtained stabilization value, as compared to the implants surface coated only with hydroxyapatite.

Keywords: implant, hydroxyapatite, Ti6Al4V, silver nanoparticles

[*Engineering of Biomaterials* 154 (2020) 9-15]

doi:10.34821/eng.biomat.154.2020.9-15

Introduction

Hip arthroplasty is one of the most commonly performed surgical procedures consisting in the complete replacement of a damaged joint by an artificial one. Such surgery is connected with introducing foreign bodies into the human internal environment with the assumption that they will meet the long-term biomechanical function and are biologically inert [1]. The effectiveness of bone loss treatment predominantly depends on the implant osseointegration [2] and the proper selection of the implant material, which can eliminate possible complications in orthopedic surgery [2].

In order to develop implantology by improving osseointegration the implant surface may be modified in several aspects, such as topography, surface chemistry, and physical surface properties (surface charge and energy) [3]. The osseointegration process ("direct structural and functional connection between the bone and the surface of the loaded implant") is a decisive factor in the success of endoprosthesis implant surgery. The binding strength between the joint and the implant is determined by the mechanical blocking and biological binding of growing bone tissue. Implants with rough surfaces or porous coatings provide excellent mechanical coupling with the surrounding bone and achieve greater stability [4,5].

Alloplastic materials, e.g. titanium, can induce different defense reactions, including implant rejection. The material is considered biocompatible when it does not cause pathological reactions in the tissues, does not emit any disintegrating substances, and - in the case of implants - it allows the bone to grow directly on the intraosseous surface [5]. One of the biocompatible materials widely used in medicine is titanium and its alloys. As the binding strength between the bone tissue and the biological surface of a titanium-based alloy is weak [6], many studies have been carried out to improve the osseointegration of titanium and the bone-implant binding. Particular attention has been paid to the combination of surface modification and applying bioactive coatings on titanium-based alloy surfaces. To strengthen the bioactivity of implant metal surfaces, hydroxyapatite (HA) is often used as a thin coating [7,8]. Unfortunately, the excellent biocompatibility of HA also allows the adhesion and reproduction of bacteria on the surface, which leads to the infection and the possible implant rejection. A bacterial infection is one of the most serious implant surgery complications that may lead to severe physical damage and the need for additional costly surgical procedures. Therefore, the incorporation of anti-bacterial components into the hydroxyapatite coating during or after the production process is of great clinical significance. An inorganic antibacterial material containing silver, copper, zinc and other metal ions has excellent properties, such as thermal stability and broad spectral antimicrobial properties. Of all the antimicrobial metal ions, silver ions not only have the best antibacterial activity including gram-positive, gram-negative bacteria, fungi and even viruses [9], but also the lowest cytotoxicity [7,10]. In contrast to the bactericidal action of silver ions, the antibacterial activity of colloidal silver particles depends on their size. The smaller the particles, the greater the antibacterial effect [11]. When nanoparticles (Np) are used, there is a huge increase in the contact surface with microbial cells and the prolonged antibacterial action is associated with a gradual release of ions from the implant surface in a process lasting up to several months [12]. Silver-based composite implants require not only sufficient bactericidal properties but also the extended and controlled release of silver from the material.

The monitored release of silver ions inhibits bacterial proliferation. The authors of [13] showed that the amount of released silver ions depends on the immersion time and the amount of nanoparticles incorporated into the polymer matrix. During the incubation, the release of silver ions increases in proportion to the square root of the fill content. Due to the polymer stability in the composite, the release does not proceed rapidly. In addition, it was proved that silver does not affect the pH of the solution of any of the tested composites, hence the tested materials are safe for bones and the surrounding tissues. The composites with higher nano addition content were more hydrophobic and had a greater roughness. What is more, as the roughness increases, the amount of released silver ions increases, and the better bactericidal efficacy is observed [13,14].

In the presented studies, powdered hydroxyapatite was sprayed onto the surface of cylindrical titanium samples (implants), then silver nanoparticles were deposited and the prototypes of the implants obtained in this way were tested for ion release during time and bone hyperplasia. The presented work examined the strength of extraction of implants from bones. The influence of nano additive on the osseointegrative properties of hydroxyapatite coatings was analyzed. For comparison, HA coated implant was used.

Materials and Methods

Production of implants with HA and HA+AgNp coatings

Titanium and titanium alloys, especially Ti6Al4V are the most attractive biocompatible alloys due to their excellent combination of mechanical properties, corrosion resistance and biocompatibility. For this reason, a titanium alloy was used as a research material. The prototype implants were made of titanium alloy Ti6Al4V (the material was obtained from 2PS Company, Montbazens Germany) coated with hydroxyapatite and with hydroxyapatite with silver nanoparticles. The titanium samples measuring 4 mm in diameter and 10 mm in length were coated with HA by the plasma spraying method in the French company 2PS. The plasma spraying was used as a traditional technique preferred by industrialists due to its moderate costs, ease of implementation and high efficiency. In addition, plasma spraying is used to produce almost all commercially available HAP coatings for orthopedic and dental implants. Schematic diagrams of the prototype implants are presented in FIG. 1. Next, the process of applying silver nanoparticles on the samples with the HA coating was carried out on a specially prepared stand (FIG. 2).

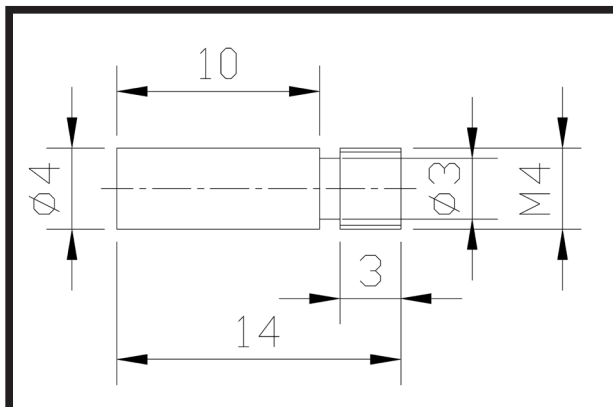

FIG. 1. Diagram of Ti6Al4V prototype implant.

The in vivo samples were fixed in a specially made holder (FIG. 2). The process of mixing the suspension was carried out at the speed of 600 rpm, using an aqueous suspension of silver particles manufactured by *Particular GmbH* (Hannover Germany) with a particle size of 66 nm and a concentration of 106 mg/l. The samples were then dried in a laboratory furnace at 70°C for 1 h.

Microscopic observations

Microscopic observations of the surface morphology of the prototype implants were conducted using an Inspect S scanning electron microscope (FEI). The amount of silver nanoparticles on the surface of the implants was monitored by SEM-EDS.

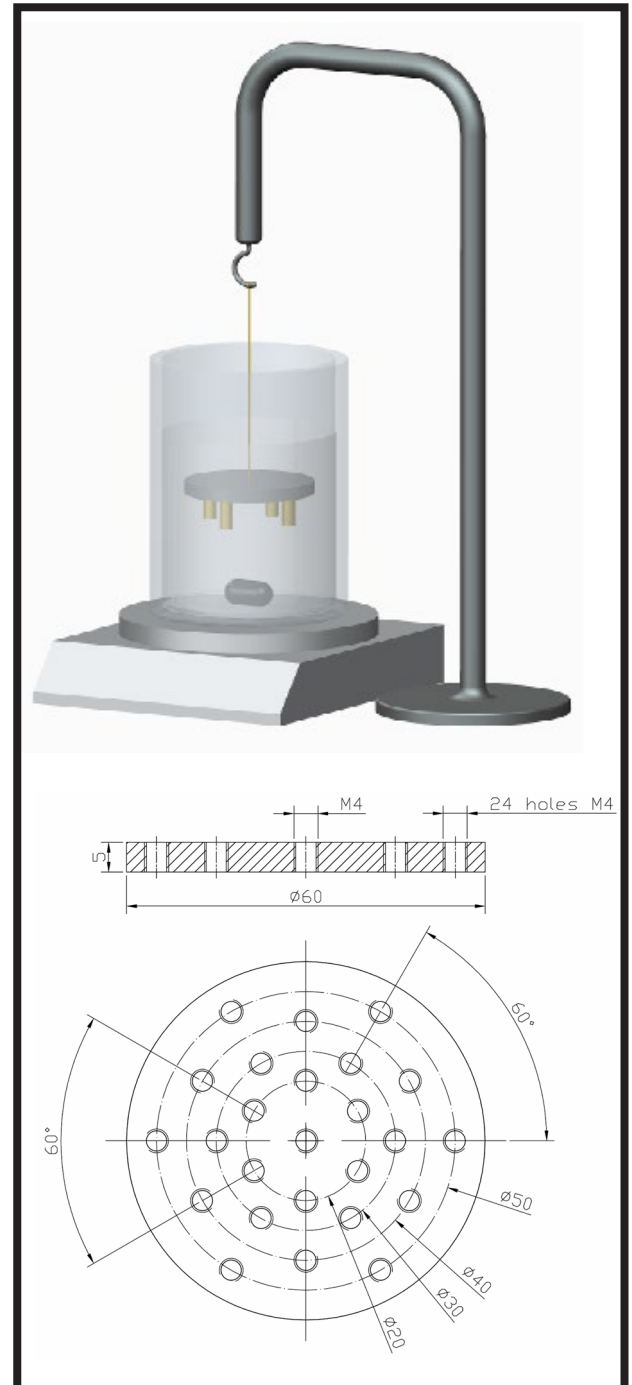

FIG. 2. Diagram of silver nanoparticle application stand and in vivo sample fixing.

Ion release studies

The first batch of the prototype implants was subjected to the ion release testing. The samples were placed with 100 ml of ultrapure water in four flat-bottomed sealed flasks. The content of silver ions was analyzed after removing the sample from the relevant flask after 12 h, 7, 14 and 21 days. The experiment was repeated three times for each period and the presented results are the average of the measurements. In addition, the ion conductivity test was performed for each of the obtained samples. The measurement was carried out at room temperature, the reference sample was ultrapure water with a conductivity of 1.28 $\mu\text{S}/\text{cm}$. Additionally, the analysis of the silver ions concentration was performed. The elements were determined by atomic absorption spectrometry with atomization in a graphite cuvette using a Varian Spectra AA 200 apparatus. The atomic absorption method with atomization in a graphite cuvette is a sensitive method useful for trace metal analysis.

In vivo studies

In vivo studies were conducted on a group of 10 New Zealand rabbits weighing between 2.3 and 3.7 kg. The animals underwent implant surgeries. Five rabbits received the implants with the hydroxyapatite coating, and the other five ones - the implants with the hydroxyapatite coating enriched with silver nanoparticles. Having immobilized the rabbit, the joint was exposed. The hair was shaved and the skin was disinfected with alcohol and iodine and prepared for the sterile operation. Then a lateral parapatellar skin incision was made extending from a level at about 1.5 cm above the patella to the tibial tuberosity. The subcutaneous tissue was incised in the same line. Then a similar curved incision was made in the fascia lata and lateral fascia of the stifle joint. Enough fascia was left on the lateral border of the patella to receive enough space for sutures when the joint is closed. After opening a joint capsule, the patella was luxated medially and the femoral trochlea was exposed. With the knee maximally flexed a full-thickness cylindrical defect was created (5 mm in diameter) at the bottom of the trochlear groove, parallel to the cortical bone, using a drill-bit and a trephine. Firstly, the predrilling was performed using a drill-bit smaller diameter and the defect was gradually enlarged to the level of 5 mm. All debris was removed and the area was flushed with saline solution. Then the titanium implant was inserted. Five rabbits received implants with initial HAP and the rest of them – the same implants but modified with AgNps. The implants were fitted at the sub-chondral bone level, beneath the surface of the adjacent articular cartilage to ensure a good connection with the bone marrow. Subsequently, the patella was repositioned and the joint capsule closed with a continuous suture pattern using Dexon 3-0. Then the fascia, subcutaneous tissue and the skin were closed in the routine manner with absorbable suture material. After the operation, all the rabbits were allowed to move freely in the cages without any splints.

To minimize the risk of post-operative infection, the animals were given an antibiotic and an anti-inflammatory drug for 5 days after the surgery. After a 2-month observation period, the animals were euthanized (blood, kidney and liver tissue samples were collected for further evaluation). A fragment of the thigh bone together with the implant was removed from each rabbit and fixed in a paraformaldehyde buffer solution with a pH of 7.4. All the implantation activities were carried out with the consent of the Ethics Committee for Experiments on Animals. All the tests were performed by the Poznan University of Medical Sciences (UMP) scientists holding proper permissions for research from the Local Bioethics Commission for Research on Animals in Poznan.

Measurements of the force of removing implants from bone

Assessment of the force used to remove the implant from the bone is a method used to evaluate the implant stability. The test is based on measuring the tensile force at which the implant is extracted from the bone - the higher the measured value, the better implant stabilization. The method also indirectly provides information on the implant stabilization in the bone.

In order to measure the force of extracting the implants from the bone, a special holder for fixing the sample was designed at the Lukasiewicz Research Network-Metal Forming Institute in Poznan. FIG. 3 shows the scheme of fixing the sample in the holder to perform a static tensile test.

The measurements were carried out using a testing machine - Instron 4483 series H1907 with a 2518-102 measuring head with a lifting capacity of 20 kN and a 500-181-20 electronic caliper (Mitutoyo). The tests were carried out at 21.5°C. The maximum force value was noted as the force needed to extract the implant from the bone. FIG. 4 shows an example of the sample, i.e. the bone fragment with the implant.

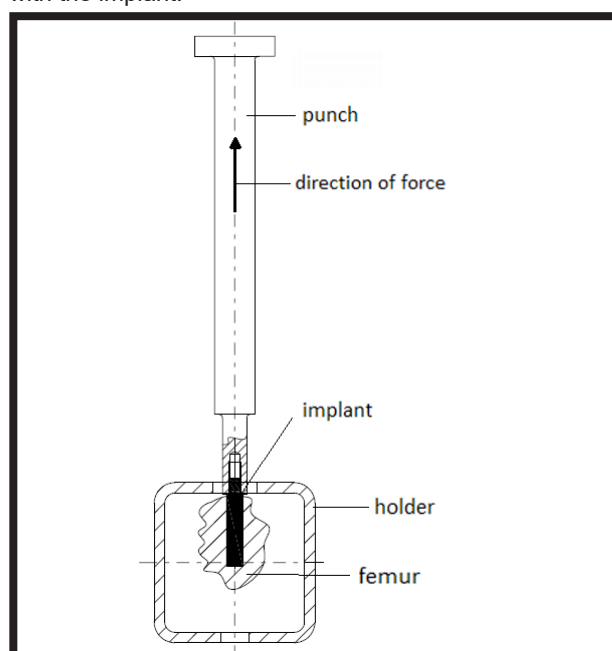

FIG. 3. Diagram of the sample fixing.



FIG. 4. The example of the in vivo sample.

Results and Discussion

The microscopic analysis of the prototype implant surface was performed. FIG. 5 shows the SEM micrographs of the hydroxyapatite coating obtained under conditions typical of the industrial process. The HA coating is characterized by low porosity and the presence of microcracks. Irregularities resulting from imperfections in the machining process are also visible. In industry the presence of several microcracks is acceptable. The spherical HA particles of a smaller size than the initial particles are also visible in the SEM micrographs. The reduction in HA grain size results from the partial melting and evaporation in the plasma stream.

The SEM micrographs of the hydroxyapatite surface after the silver nanoparticle application process are shown in FIG. 6; the arrows indicate the nAg particles occurring on the surface. The distribution of silver nanoparticles on the implant surface was virtually uniform. In addition, no significant agglomerates were observed, only those that occur sporadically. The elemental composition analysis showed the presence of Ag nanoparticles at the level of 2%. The results of EDS analysis are presented in FIG. 7.

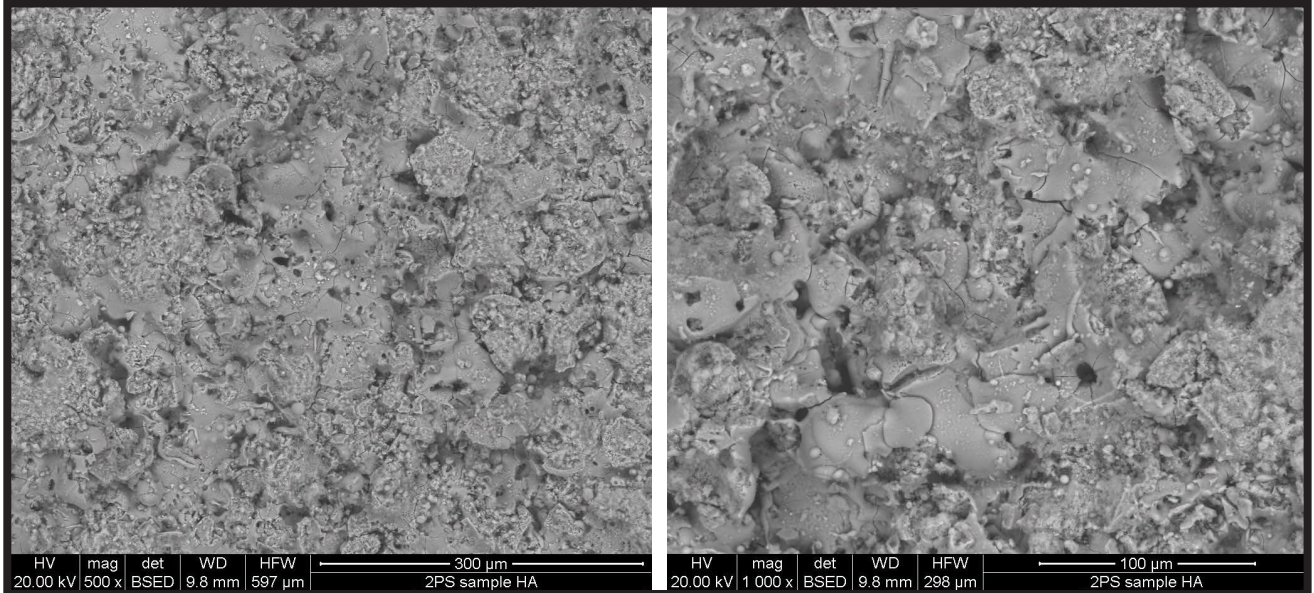

FIG. 5. SEM micrographs of hydroxyapatite coating applied on Ti6Al4V.

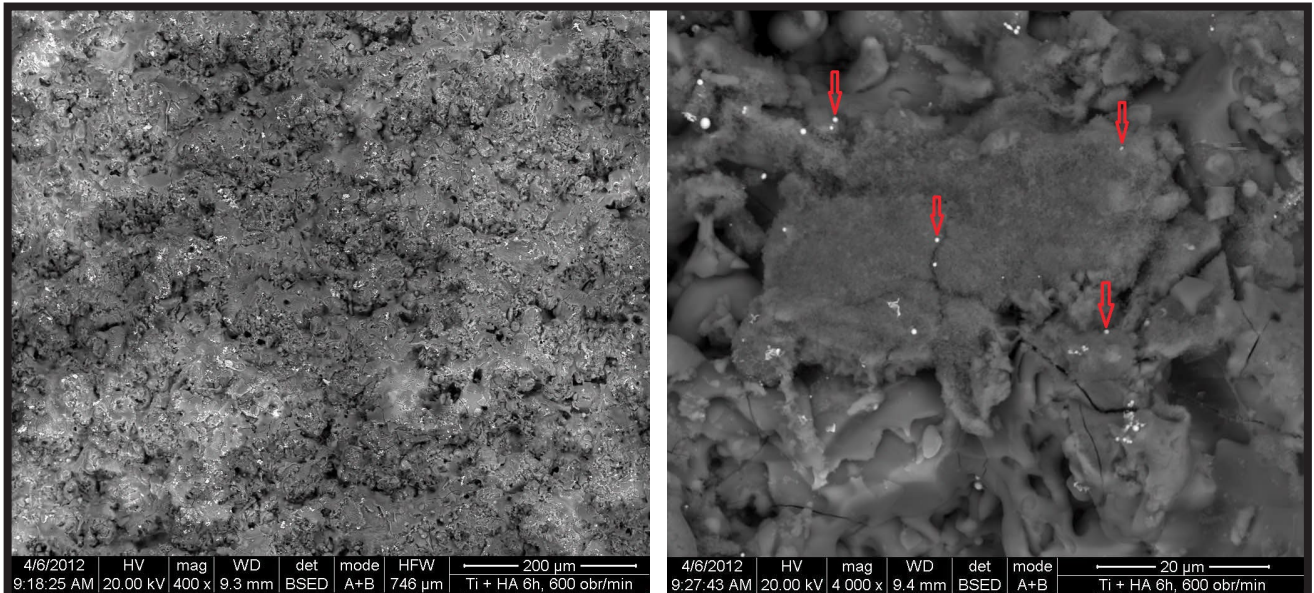

FIG. 6. SEM micrographs of hydroxyapatite coating with silver nanoparticles on the surface of Ti6Al4V, with different magnification.

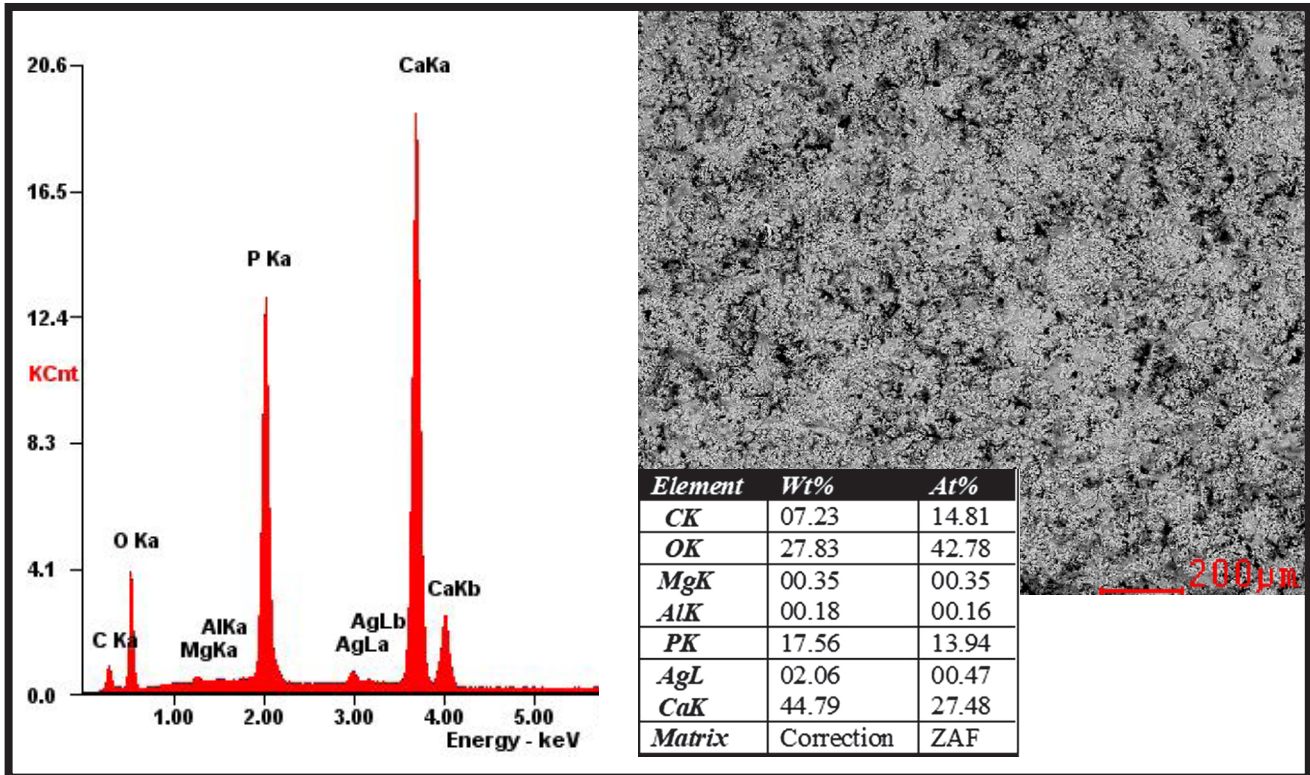

FIG. 7. Elemental composition analysis of the coating.

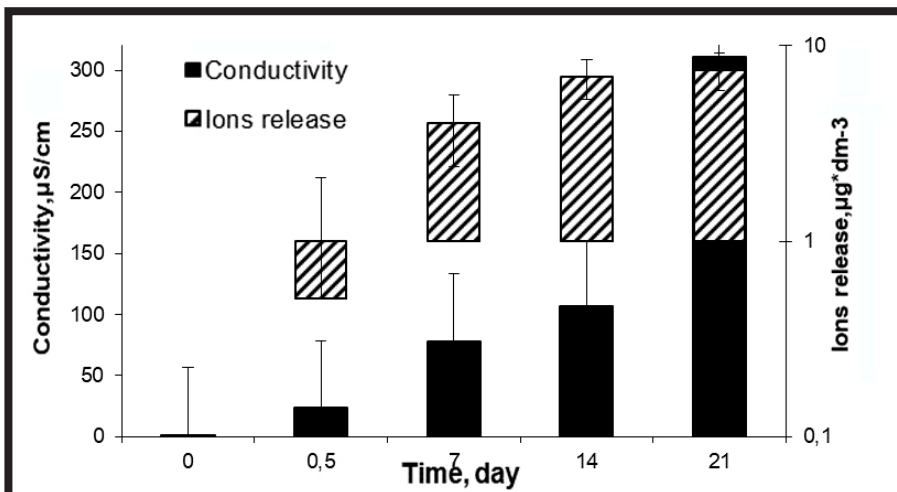

FIG. 8. Ion conductivity as a function of incubation time.

In addition, the ion conductivity test was carried out for the obtained prototypes. The measurement was performed at room temperature, and the reference sample was ultrapure water with a conductivity of $1.28 \mu\text{S}/\text{cm}$ (time equal to 0). The dependence of the ionic conductivity on time and the dependence of silver ion content on the incubation time are shown in FIG. 8.

The analysis of the data presented in FIG. 8 allowed the authors to conclude that with the longer the incubation time of the implants with the HA+AgNp coating, the higher the ionic conductivity and the content of released silver ions. After 21 days, the conductivity of the solution reached the value of $311 \mu\text{S}/\text{cm}$ and the concentration of silver ions was $7.54 \mu\text{g}\cdot\text{dm}^{-3}$. This proved that over time an increasing number of ions got released into the solution, including silver ions when keeping the tested material in ultrapure water. During the first 7 days, there was an increase in the concentration of silver ions to the level of $3.52 \mu\text{g}\cdot\text{dm}^{-3}$, in the following 7 days the concentration increased by $2.89 \mu\text{g}\cdot\text{dm}^{-3}$ and in the last week - by $1.32 \mu\text{g}\cdot\text{dm}^{-3}$.

During the test, however, no changes in the pH value were observed, i.e. the acid-base balance of the liquid was not disturbed. For this reason, it may be assumed that the material is safe for adjacent bones and tissues of the human body. Similar results were obtained by the authors of the work [13].

Measurements of the implant stability in bone in animal models can be used to assess the degree and quality of osseointegration. Bone remodeling is a lifelong process, the alternating occurrence of bone resorption and new bone formation. In the peri-implant area, the remodeling process is distinctly observed after 6-12 weeks after the surgical implantation [15]. The in vivo tests confirmed that the prototypes of the Ti6Al4V+HA and Ti6Al4V+HA+AgNp implants exhibited good surgical functionality and remained in the place of implantation. After the operation, all the animals moved freely in their cages, the majority of rabbits had mild swelling around the suture but they did not stumble. After two weeks, all the operated animals were in good general condition, with no clinical signs of dysfunction.

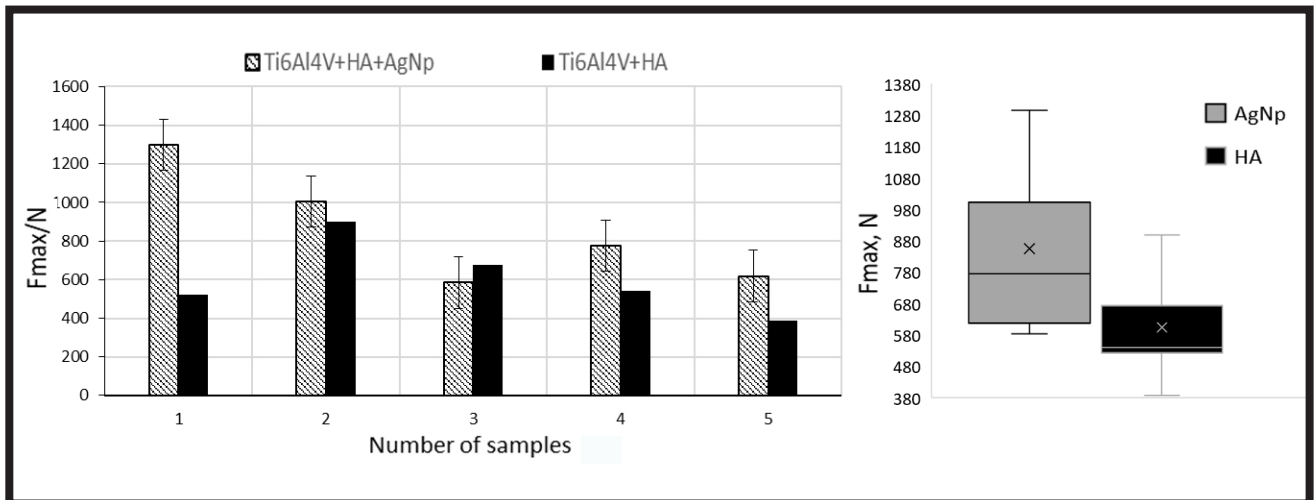

FIG. 9. Values of forces needed to pull out implants with standard deviation (A) and results of statistical analysis (B).

The implants did not induce any negative or unexpected reactions within the adjacent soft tissues or bones. After two months, the implants were removed – FIG. 9 shows the values of the forces needed to remove the implants from the bone.

When interpreting the obtained data, it was found that the extraction force for the implants was different and for both groups of implants it ranged from 388 to 1297 N. The extraction force for the implants with the hydroxyapatite coating and silver nanoparticles was slightly higher when compared to the implants with the hydroxyapatite coating. The mean, without the extreme values, was 800 N and 580 N, respectively for the Ti6Al4V+HA+AgNp and Ti6Al4V+HA implants. The median value for the AgNp samples was 775 N, and for HA was 541 N. The box graph (FIG. 9B) shows the dispersion of the results obtained and indicates that the data obtained was asymmetrical. Despite the large dispersion of results for the AgNp samples, the smallest value for the AgNp sample (585 N) was still greater than the median for HA samples.

The formation of the strong implant-bone bonding is critical to the clinical success of orthopedic procedures. The structure of the implant surface can play a decisive role in creating such a bonding. A rough surface and open pores of the coating favour the formation of a strong adhesive bond between the implant and the bone due to tissue interference in the implant interior and its connection to the bone. In [16] the authors state that strong bone overgrowth is also associated with the method of coating application and the lower residual stress occurring in the HA coating.

In the presented study, the implants surface modification positively influenced the obtained stabilization value, in comparison with the implants with the reference surface, i.e. covered only with hydroxyapatite. Although the antimicrobial properties of AgNp are well documented, their effect on the osseointegration of orthopedic implants is not well understood [17]. Nevertheless, it is believed that the presence of silver nanoparticles accelerates the healing process and reduces the duration of inflammation. Due to this phenomenon, bone cells start to overgrow faster, creating a stronger connection. The findings suggest a beneficial effect of silver nanoparticles on processes occurring in the peri-implant area, but this requires confirmation in further studies. The authors are aware that the tests should be carried out on a larger number of samples, but for ethical reasons, they have been carried out on the smallest possible number of animals.

Conclusions



The following conclusions were made on the basis of the conducted research:

- as a result of applying HA, a coating was obtained that complies with the specification of the plasma spray process,
- on the hydroxyapatite coating with silver nanoparticles, a homogeneous distribution of silver nanoparticles with sporadically occurring agglomerates is observed,
- with the extension of the sample incubation time, an increasing number of ions is released into the liquid and this process occurs gradually,
- surface modification with silver nanoparticles has a positive effect on the implant stability in the bone. The average force (without the extreme values) needed to remove the implant with the HA+AgNp coating from the bone is 800 N, which is 220 N higher when compared to the implants with the reference surface.

Acknowledgments

The research leading to these results has received funding from the European Union Seventh Framework Programme FP7/2007-2013 under grant agreement No. NMP4-CP-2011-263942 (NANOMINING Project “Development of New Nanocomposites Using Materials from Mining Industry”). Research work financed from public funds for science in period 2011-2013, granted for realization of international co-financed project.

ORCID iDs

- J. Sulej-Chojnacka:  <https://orcid.org/0000-0003-0158-7125>
 W. Woźniak:  <https://orcid.org/0000-0002-8173-131X>
 D. Andrzejewski:  <https://orcid.org/0000-0003-0798-1676>

References

- [1] Gierzyńska-Dolna M., Lijewski M.: Badania tribologicznych właściwości biomateriałów i implantów. *Obróbka Plastyczna Metali* XXIII Nr 3 (2012).
- [2] Borkowski L., Pawłowska M., Polkowska I., Karpiński M., Słowik T., Piersisk T., Matuszewski Ł., Ślósarczyk A., Ginalska G.: Histological and radiological analysis of rabbit bones after implantation of CHAP-glucan composite. *Engineering of Biomaterials* 114 (2012) 28-33.
- [3] Karlsson J., Jimbo R., Fathali H.M., Schwartz-Filho H.O., Hayashi M., Halvarsson M., Wennerberg A., Andersson M.: In vivo biomechanical stability of osseointegrating mesoporous TiO₂ implants. *Acta Biomaterialia* 8 (2012) 4438-4446.
- [4] Dan-Jae L., Chien-Ping J., Shu-Huei H., Yin-Chun T., Hsiang-Shu Y., Wen-Cheng Ch., Jiin-Huey Ch.L.: Mechanical testing and osteointegration of titanium implant with calcium phosphate bone cement and autograft alternatives. *Journal of the mechanical behavior of biomedical materials* 4 (2011) 1186-1195.
- [5] Makuch K., Koczorowski R.: Biokompatybilność tytanu oraz jego stopów wykorzystywanych w stomatologii. *Dent. Med. Probl.* 47(1) (2010) 81-88.
- [6] Chung C.J., Su R.T., Chu H.J., Chen H.T., Tsou H.K., He J.L.: Plasma electrolytic oxidation of titanium and improvement in osseointegration. *Journal of Biomedical Materials Research Part B: Applied Biomaterials* 101(6) (2013) 1023-1030.
- [7] Zhang X., Chaimayo W., Yang C., Yao J., Miller B.L., Yates M.Z.: Silver-hydroxyapatite composite coatings with enhanced antimicrobial activities through heat treatment. *Surface & Coatings Technology* 325 (2017) 39-45.
- [8] Agarwal R., García A.J.: Biomaterial strategies for engineering implants for enhanced osseointegration and bone repair: *Advanced Drug Delivery Reviews* 94 (2015) 53-62.
- [9] Speruda M., Kędziora A., Bugla-Płoskońska G.: Antybakteryjne działanie nanocząstek srebra syntetyzowanych metodą zielonej chemii. *Medycyna Doświadczalna i Mikrobiologia* 69 (2017) 281-288.
- [10] Song L., Xiao Y.F., Gan L., Wu Y., Wu F., Gu Z.W.: The effect of antibacterial ingredients and coating microstructure on the antibacterial properties of plasma sprayed hydroxyapatite coatings. *Surface and Coatings Technology* 206(11-12) (2012) 2986-2990.
- [11] Guzman M., Dille J., Godet S.: Synthesis and antibacterial activity of silver nanoparticles against gram-positive and gram-negative bacteria. *Nanomedicine: Nanotechnology, Biology, and Medicine* 8 (2012) 37-45.
- [12] Salem W.M., Haridy M., Sayed W.F., Hassan N.H.: Antibacterial activity of silver nanoparticles synthesized from latex and leaf extract of *Ficus sycomorus*. *Industrial Crops and Products* 62 (2014) 228-234.
- [13] Ziąbka M., Merta A., Król W., Bobrowski A., Chłopek J.: High Density Polyethylene Containing Antibacterial Silver Nanoparticles for medical Applications. *Macromolecular Symposia* 315 (2012) 218-225.
- [14] Dubnika A., Loca D., Rudovica V., Bharat Parekh M., Berzina-Cimdina L.: Functionalized silver doped hydroxyapatite scaffolds for controlled simultaneous silver ion and drug delivery. *Ceramics International* 43(4) (2017) 3698-3705.
- [15] Li J., Jansen J.A., Walboomers X.F., van den Beucken J.J.: Mechanical aspects of dental implants and osseointegration: A narrative review. *Journal of the mechanical behavior of biomedical materials* 103 (2020) 103574.
- [16] Yang Y.Ch., Yang Ch.Y.: Mechanical and histological evaluation of a plasma sprayed hydroxyapatite coating on a titanium bond coat. *Ceramics International* 39 (2013) 6509-6516.